

# JVC

## SERVICE MANUAL

MODEL  
**A-X30**

STEREO INTEGRATED AMPLIFIER

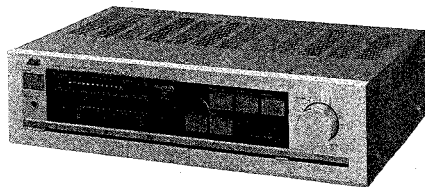

# Contents

	Page
1. Specifications .....	1
2. Main Parts Locations .....	2
3. Adjustment Procedures .....	3
3-(1) Power Level Indicator Adjustment .....	3
3-(2) Power Amplifier Current Adjustment .....	3
4. Exploded Views and Part Numbers .....	4
5. Block Diagram .....	5
6. Printed Circuit Board Ass'y and Parts List .....	6
6-(1) TXX-313□ Equalizer Amp P.C. Board Ass'y .....	6
6-(2) TXX-314□ Main Amp P.C. Board Ass'y .....	8
6-(3) TDS-8□ Fluorescent Lamp P.C. Board Ass'y .....	11
6-(4) TPS-255E AC P.C. Board Ass'y .....	11

	Page
6-(5) TPS-317□ Fuse P.C. Board Ass'y .....	12
6-(6) TPS-318A Voltage Selector P.C. Board Ass'y .....	12
7. A-X30 Schematic Diagram .....	13
8. Packing Materials and Part Numbers .....	15
9. Accessories List .....	15
10. Parts List with Specified Numbers for Designated Areas .....	16

Warning: When replacing the parts marked with , be sure to use the designated parts to ensure safety.

## 1. Specifications

**CIRCUITRY** : "Super-A" power amplifier

### ALLOVER CHARACTERISTICS

Output power (VIDEO/AUX IN SP. OUT)

1 kHz : 42 watts RMS per channel min.  
(8 ohms, 0.007% total harmonic distortion measured by JVC Audio Analyze System)  
50 watts RMS per channel min.  
(8 ohms, 0.7% total harmonic distortion.)

20 Hz - 20 kHz : 40 watts RMS per channel min.  
(both channels driven into 8 ohms from 20 Hz to 20 kHz, with no more than 0.007% total harmonic distortion.)

Total harmonic distortion (VIDEO/AUX IN SP. OUT) : 0.007% (20 Hz - 20 kHz, 8 ohms) at 40 watts

Intermodulation distortion (VIDEO/AUX IN SP. OUT) : 0.007% (60 Hz: 7 kHz = 4 : 1, 8 ohms) at 40 watts

Power band width (VIDEO/AUX IN SP. OUT) : 10 Hz - 30 kHz (IHF, 0.02%, 8 ohms both channels driven)

Frequency characteristic : 10 Hz - 100 kHz  
+0.5, -3 dB (8 ohms)

Damping factor : 50 (1 kHz, 8 ohms)

Input terminals  
Input sensitivity/impedance (1 kHz)  
PHONO : 2.5 mV/47 kohms  
TUNER, VIDEO/AUX, TAPE : 150 mV/40 kohms

Signal-to-noise ratio  
PHONO : 72 dB  
TUNER, VIDEO/AUX, TAPE : 104 dB  
(IHF A Network short circuit)

PHONO : 81 dB (IHF A-202, Rec Out)  
TUNER, VIDEO/AUX, TAPE : 75 dB (IHF A-202, Speaker Out)

Tone controls : TREBLE: ±8 dB (10 kHz)  
BASS: ±8 dB (100 Hz)  
Loudness controls : 100 Hz: +6 dB/10 kHz: +4 dB (at VOLUME -30 dB)

### EQUALIZER

PHONO overload capacity : 150 mV (1 kHz, 0.007% THD)  
PHONO RIAA deviation : ±0.5 dB (20 Hz - 15 kHz)

### GENERAL

Power source :

Areas	Line Voltage & Frequency	Power consumption
U.S.A. & Canada	AC 120V 60 Hz	190watts
Europe	AC 220V ~ 50 Hz	300watts
U.K. & Australia	AC 240V ~ 50 Hz	300watts
U.S. Military Market & Other Countries	AC 110/120/220/240V ~ Selectable 50/60 Hz	300watts

Dimensions and Weight :

Height	Dimensions (cm)		Weight (kg/lbs)
	Width	Depth	
11.7 (4-5/8")	43.5 (17-1/8")	30.3 (11-15/16")	6.0/13.2

*Design and specifications subject to change without notice.*

## 2. Main Parts Locations

### 2-(1) Top View

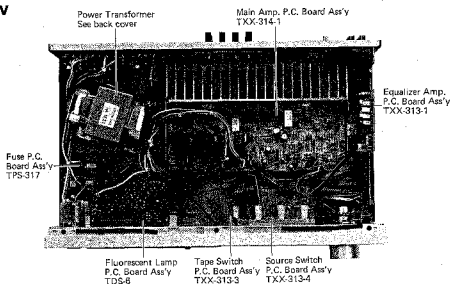

Fig. 1

### 2-(2) Front View

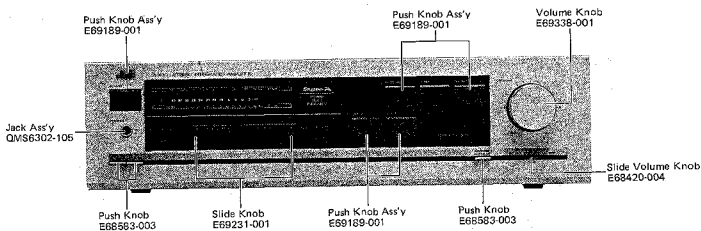

Fig. 2

### 2-(3) Rear View

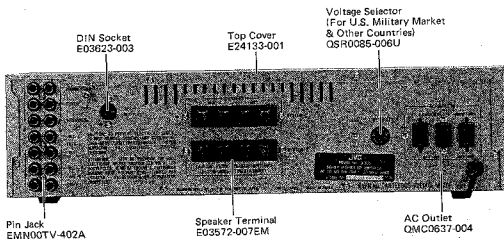

Fig. 3

## 3. Adjustment Procedures

### 3-(1) Power Level Indicator Adjustment

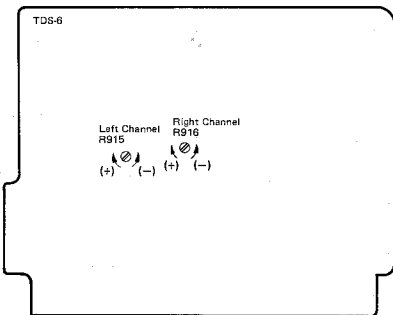

Fig. 4

#### Power Level Indicator Adjustment

1. Turn the semi-fixed resistors (R915, R916) counterclockwise fully, before switching the power ON.
2. With the output voltage at 14.1 V 1 kHz, adjust the indicator so that its -3 dB point lights.

Left channel : R915  
Right channel : R916

### 3-(2) Power Amplifier Current Adjustment

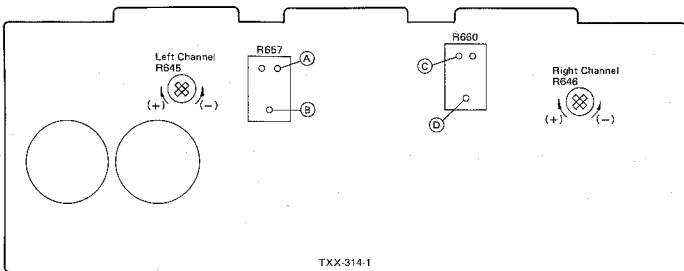

Fig. 5

1. Before turning on the power, turn the semi-fixed resistors (R645 for L channel and R646 for R channel) of the power amplifier circuit board fully counterclockwise.

2. Adjust the semi-fixed resistors (R645 and R646) so that the voltage at the following test points of the power amplifier circuit board is within a range of 5 mV - 6 mV after the power is turned on.

L channel: Measure the voltage between test point (A) (emitter of Q623) and output at the test point (B).

R channel: Measure the voltage between test point (C)

(emitter of Q624) and output at the test point (D).

3. Readjust resistors R645 and R646 about 5 minutes after the power is turned on (the heat sink temperature must be sufficiently high) so that the voltage at the test points becomes 11 mV.

Confirm that the voltage does not vary when the heat sink temperature increases further.

Note: Be sure to perform the measurement with the probes and cabinet of the measuring equipment separated from the grounding terminals of A-X30 or of other measuring equipment.



## 5. Block Diagram

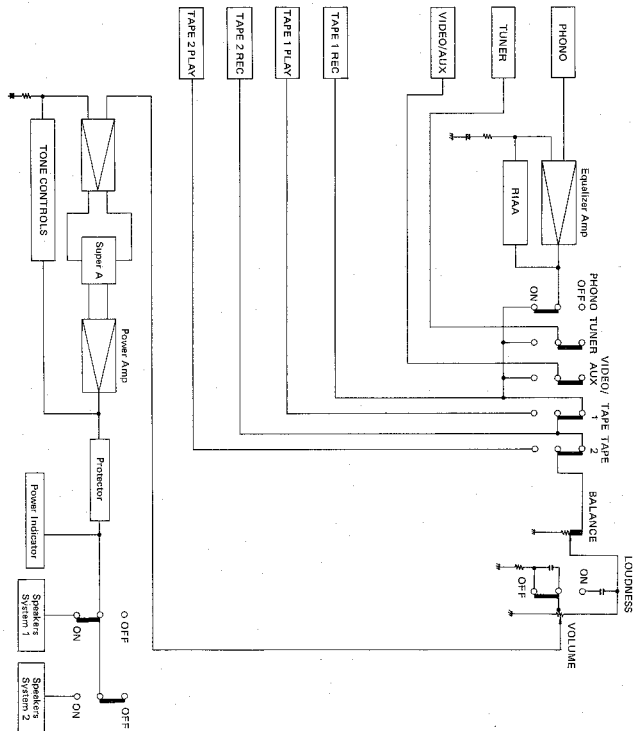

Fig. 6

## 6. Printed Circuit Board Ass'y and Parts List

### 6-(1) TXX-313 Equalizer Amp P.C. Board Ass'y

Note: TXX-313□-1 varies according to the areas employed. See note (1) when placing an order.

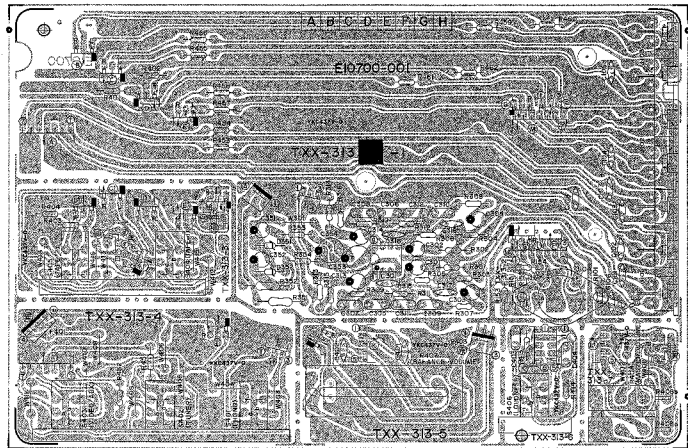

Fig. 8

#### Each Individual P.C. Board Location

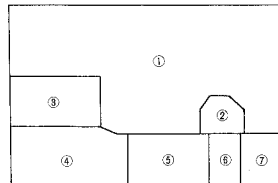

Fig. 9

- ① TXX-313-1 EQ Amp & Power Supply P.C. Board Ass'y
- ② TXX-313-2 DIN P.C. Board Ass'y
- ③ TXX-313-3 Tape Switch P.C. Board Ass'y
- ④ TXX-313-4 Source Switch P.C. Board Ass'y
- ⑤ TXX-313-5 Balance P.C. Board Ass'y
- ⑥ TXX-313-6 Loudness P.C. Board Ass'y
- ⑦ TXX-313-7 Volume P.C. Board Ass'y

#### Note (1)

Designated Area	P.C. Board Ass'y
U.S.A. & Canada	TXX-313□
W. Germany	TXX-313□
All Other Areas	TXX-313□

Note (2) The symbols (禁, 断, 自, ...) etc.) on P.C. Board surface are factory process only.

### Integrated Circuits

Item No.	Part Number	Rating	Description	Maker
IC301	NJM4560D-X			JRC

### Diodes

Item No.	Part Number	Rating	Description	Maker
D351	RD15EB3			NEC
D352	RD15EB3			"

### Capacitors

Item No.	Part Number	Rating	Description	Maker
C101	QCF21HP-223	0.022 $\mu$ F 50 V	Ceramic	
C103	QCS21HJ-101	100 pF "	" (for C)	
C106	QCF21HP-473	0.047 $\mu$ F "	" (for A,B)	
C107	QCS21HJ-101	100 pF "	" (for C)	
C301	QET51HR-475	4.7 $\mu$ F "	Electrolytic	
C302	QET51HR-475	" "	"	
C303	QET51AR-107	100 $\mu$ F 10 V	"	
C304	QET51AR-107	" "	"	
C305	QFM81HJ-272	2700 pF 50 V	Mylar	
C306	QFM81HJ-272	" "	"	
C307	QFM81HJ-472	4700 pF "	"	
C308	QFM81HJ-472	" "	"	
C309	QFM81HJ-822	8200 pF "	"	
C310	QFM81HJ-822	" "	"	
C311	QFM81HJ-183	0.018 $\mu$ F "	"	
C312	QFM81HJ-183	" "	"	
C313	QET51HR-475	4.7 $\mu$ F "	Electrolytic	
C314	QET51HR-475	" "	"	
C315	See below	" "	"	
C316	See below	" "	"	
C317	See below	" "	"	
C318	See below	" "	"	
C351	QET51CR-226H	22 $\mu$ F 16 V	Electrolytic	
C352	QET51CR-226H	" "	"	
C353	QET51CR-107H	100 $\mu$ F 10 V	"	
C354	QET51CR-107H	" "	"	
C401	OCS21HJ-221	220 pF 50 V	Ceramic	
C402	OCS21HJ-221	" "	"	
C403	QFM81HK-333	0.033 $\mu$ F "	Mylar	
C404	QFM81HK-333	" "	"	

### For TXX-313A/TXX-313B

Item No.	Part Number	Rating	Description	Maker
C315	OCS21HJ-101	100 pF 50 V	Ceramic	
C316	OCS21HJ-101	" "	"	
C317	OCS21HJ-101	" "	"	
C318	OCS21HJ-101	" "	"	

### For TXX-313C

Item No.	Part Number	Rating	Description	Maker
C315	OCS21HJ-151	150 pF 50 V	Ceramic	
C316	OCS21HJ-151	" "	"	
C317	OCS21HJ-471	470 pF "	"	
C318	OCS21HJ-471	" "	"	

### Resistors

Item No.	Part Number	Rating	Description	Maker
R101	QRD141J-4R7S	4.7 $\Omega$ 1/4 W	Carbon (for A,B)	
R151	QRD141J-823S	82 k $\Omega$ "	" (for B,C)	
R152	QRD141J-823S	82 k $\Omega$ "	" ( " )	
R153	QRD141J-334S	330 k $\Omega$ "	" ( " )	
R154	QRD141J-334S	330 k $\Omega$ "	" ( " )	
R301	QRD141J-272S	2.7 k $\Omega$ "	"	
R302	QRD141J-272S	2.7 k $\Omega$ "	"	
R303	QRD141J-104S	100 k $\Omega$ "	"	
R304	QRD141J-104S	100 k $\Omega$ "	"	
R305	QRD141J-104S	100 k $\Omega$ "	"	
R306	QRD141J-104S	100 k $\Omega$ "	"	
R307	QRD141J-221S	220 $\Omega$ "	"	
R308	QRD141J-221S	220 $\Omega$ "	"	
R309	QRD141J-103S	10 k $\Omega$ "	"	
R310	QRD141J-103S	10 k $\Omega$ "	"	
R311	QRD141J-134S	130 k $\Omega$ "	"	
R312	QRD141J-134S	130 k $\Omega$ "	"	
R313	QRD141J-561S	560 $\Omega$ "	"	
R314	QRD141J-561S	560 $\Omega$ "	"	
R315	QRD141J-104S	100 k $\Omega$ "	"	
R316	QRD141J-104S	100 k $\Omega$ "	"	
R351	QRG017J-182S	1.8 k $\Omega$ 1 W	Oxide Metal Film $\Delta$	
R352	QRG017J-182S	1.8 k $\Omega$ "	" $\Delta$	
R353	QRD141J-820S	82 $\Omega$ 1/4 W	Carbon	
R354	QRD141J-820S	82 $\Omega$ "	"	
R401	QRD141J-106S	1 M $\Omega$ "	"	
R402	QRD141J-106S	1 M $\Omega$ "	"	
R403	QRD141J-106S	1 M $\Omega$ "	"	
R404	QRD141J-106S	1 M $\Omega$ "	"	
R407	QVT1CGM-1F5	250 k $\Omega$ (MN)	Slide Volume	
R408	QVCA2B-AF5V	250 k $\Omega$ (B)	Variable	
R413	QRD141J-223S	22 k $\Omega$ 1/4 W	Carbon	
R414	QRD141J-223S	22 k $\Omega$ "	"	
R451	QRD141J-331S	330 $\Omega$ "	"	
R452	QRD141J-331S	330 $\Omega$ "	"	
R453	QRD141J-331S	330 $\Omega$ "	"	
R454	QRD141J-331S	330 $\Omega$ "	"	
R455	QRD141J-331S	330 $\Omega$ "	"	
R456	QRD141J-331S	330 $\Omega$ "	"	
R457	QRD141J-331S	330 $\Omega$ "	"	
R458	QRD141J-331S	330 $\Omega$ "	"	

### Others

Item No.	Part Number	Rating	Description	Maker
	EWR23C-20NN		Flat Wire Assy	
	EWR23C-25NN		Flat Wire Assy	
	EWR37A-25NN		Flat Wire	
	EWR33A-15NN		Flat Wire Assy	
	EWR37A-15NN		Flat Wire (for B,C)	
	EWR23C-16NN		Flat Wire Assy	
	EWR35A-10NN		Flat Wire Assy	
	EWT011-002		Terminal Wire Assy (for A,B)	
J101	EMN00TV-602A		6P Pin Jack	
J102	EMN00TV-402A		Pin Jack Assy	
J103	EMN00TV-402A		Pin Jack Assy	
J104	E03623-003		Din Socket (for B,C)	
J402	EWS017-038		Socket Wire Assy	
J404	EWS013-114		Socket Wire Assy	
P301	QMV5005-003		3P Plug Assy	
P401	QMV5005-004		4P Plug Assy	
P403	QMV5004-003		3P Plug Assy	
S401	OST23A2-E01		Push Switch	
S404	OST22A1-E01		Push Switch	
S406	QSP0219-051		Push Switch	
	E10700-001		Circuit Board	

## 6-(2) TXX-314 □ Main Amp P.C. Board Ass'y

Note: TXX-314□-1 varies according to the areas employed. See note (1) when placing an order.

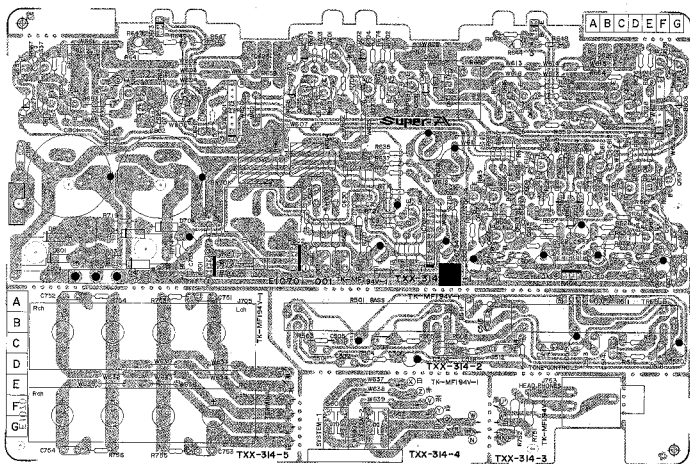

Fig. 10

### Each Individual P.C. Board Location

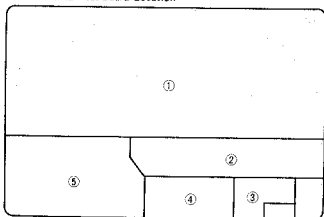

Fig. 11

- ① TXX-314-1 Pre Amp P.C. Board Ass'y
- ② TXX-314-2 Tone P.C. Board Ass'y
- ③ TXX-314-3 Phones P.C. Board Ass'y
- ④ TXX-314-4 Speaker Switch P.C. Board Ass'y
- ⑤ TXX-314-5 Speaker Terminal P.C. Board Ass'y

### Note (1)

Designated Areas	P.C. Board Ass'y
W. Germany	TXX-314□-1
All Other Areas	TXX-314□-1

Note (2) The symbols ( 黒 , 黒 , 白 ... etc.) on P.C. Board surface are factory process only.



### Transistors

Item No.	Part Number	Rating	Description	Maker
Q601	2SC2240(A,B)			Toshiba
Q602	2SC2240(A,B)			"
Q603	2SC2240(A,B)			"
Q604	2SC2240(A,B)			"
Q605	2SA1084(D,E)			Hitachi
Q606	2SA1084(D,E)			"
Q607	2SA1084(D,E)			"
Q608	2SA1084(D,E)			"
Q609	2SA1084(D,E)			"
Q610	2SA1084(D,E)			"
Q611	2SC2548(E,F)			"
Q612	2SC2548(E,F)			"
Q613	2SD636(Q,R)			Matsushita
Q614	2SD636(Q,R)			"
Q615	2SC2240(GR,BL)			Toshiba
Q616	2SC2240(GR,BL)			"
Q617	2SA970(GR,BL)			"
Q618	2SA970(GR,BL)			"
Q619	2SC2235(O,Y)			"
Q620	2SC2235(O,Y)			"
Q621	2SA965(O,Y)			"
Q622	2SA965(O,Y)			"
Q623	2SD718L(R,O)			"
Q624	2SD718L(R,O)			"
Q625	2SB688L(R,O)			"
Q626	2SB688L(R,O)			"
Q631	2SC945A(P,O)			NEC
Q632	2SC945A(P,O)			"
Q633	2SC945A(P,O)			"
Q634	2SC945A(P,O)			"
Q635	2SA733A(P,O)			"
Q636	2SA733A(P,O)			"
Q637	2SA733A(P,O)			"
Q638	2SA733A(P,O)			"
Q701	2SC2240(GR,BL)			Toshiba
Q702	2SC2240(GR,BL)			"
Q703	2SA970(GR,BL)			"

### Integrated Circuits

Item No.	Part Number	Rating	Description	Maker
IC601	VC5022(X,Y)			Rohm
IC602	VC5022(X,Y)			"
IC701	TA7317P			Toshiba

### Diodes

Item No.	Part Number	Rating	Description	Maker
D601	1S2076-31			Hitachi
D602	1S2076-31			"
D603	RD9.1EB3			NEC
D605	1S2076-31			Hitachi
D606	1S2076-31			"
D607	1S2076-31			"
D608	1S2076-31			"
D701	1S2076-31			"
D702	1S2076-31			"
D703	1S2076-31			"
D704	ERB12-02RKL1			Fuji
D801	S3V20F			Shindengen
D802	S3V20F			"
D803	S3V20F			"
D804	S3V20F			"

### Coils

Item No.	Part Number	Rating	Description
L601	EQL0001-1R0		Choke Coil
L602	EQL0001-1R0		Choke Coil

### Capacitors

Item No.	Part Number	Rating	Description
C501	QFM81HK-153	0.015 $\mu$ F 50 V	Mylar
C502	QFM81HK-153	" " "	"
C503	QFM81HK-823	0.082 $\mu$ F " "	"
C504	QFM81HK-823	" " "	"
C505	QET51ER-106	10 $\mu$ F 25 V	Electrolytic
C506	QET51ER-106	" " "	"
C511	QFM81HK-332	3300 pF 50 V	Mylar
C512	QFM81HK-332	" " "	"
C513	QFM81HK-183	0.018 $\mu$ F " "	"
C514	QFM81HK-183	" " "	"
C515	QCS21HJ-221	220 pF " "	Ceramic
C516	QCS21HJ-221	" " "	"
C517	QFM81HK-122	1200 pF " "	Mylar
C518	QFM81HK-122	" " "	"
C519	QET51ER-106	10 $\mu$ F 25 V	Electrolytic
C520	QET51ER-106	" " "	"
C601	QET51HR-475	4.7 $\mu$ F 50 V	"
C602	QET51HR-475	" " "	"
C603	QET51CR-476	47 $\mu$ F 16 V	"
C604	QET51CR-476	" " "	"
C605	QCS21HJ-101	100 pF 50 V	Ceramic
C606	QCS21HJ-101	" " "	"
C607	QCS21HJ-561	560 pF " "	"
C608	QCS21HJ-561	" " "	"
C609	QCS21HJ-3R0	3 pF " "	"
C610	QCS21HJ-3R0	" " "	"
C611	QCS21HJ-470	47 pF " "	"
C612	QCS21HJ-470	" " "	"
C613	QCS21HJ-100	10 pF " "	"
C614	QCS21HJ-100	" " "	"
C615	QFM81HJ-332	3300 pF " "	Mylar
C616	QFM81HJ-332	" " "	"
C617	QET51HR-107	100 $\mu$ F " "	Electrolytic
C618	QET51HR-107	" " "	"
C621	QFM81HK-103	0.01 $\mu$ F " "	Mylar
C622	QFM81HK-103	" " "	"
C625	QCS21HJ-680	68 pF " "	Ceramic
C626	QCS21HJ-680	" " "	"
C627	QCS21HJ-680	" " "	"
C628	QCS21HJ-680	" " "	"
C629	QFM81HJ-473	0.47 $\mu$ F " "	Mylar
C630	QFM81HJ-473	" " "	"
C631	QFM81HJ-473	" " "	"
C632	QFM81HJ-473	" " "	"
C633	QET51HM-106	10 $\mu$ F " "	Electrolytic
C635	QCS21HJ-101	100 pF " "	Ceramic
C636	QCS21HJ-101	" " "	"
C701	QET51AR-107	100 $\mu$ F 10 V	Electrolytic
C702	QET51HM-226	22 $\mu$ F 50 V	"
C703	QE2046-226	2.2 $\mu$ F " "	"
C704	QET51ER-226	22 $\mu$ F 25 V	"
C751	QFM81HK-103	0.01 $\mu$ F 50 V	Mylar
C752	QFM81HK-103	" " "	"
C753	QFM81HK-103	" " "	"
C754	QFM81HK-103	" " "	"
C801	QEW81HA-878	8700 $\mu$ F " "	Electrolytic
C802	QEW81HA-878	" " "	"
C803	QF20075-104	0.1 $\mu$ F " "	Film
C804	QCE22HP-103	0.01 $\mu$ F 500V	Ceramic
C805	QCY21HK-102	1000 pF 50 V	" (for B)

## Resistors

Item No.	Part Number	Rating	Description
R501	QV25010-102	100 kΩ (C)	Slide Volume
R503	QRD141J-203S	20 kΩ 1/4 W	Carbon
R504	QRD141J-203S	" "	" "
R505	QRD141J-362S	3.6 kΩ "	" "
R506	QRD141J-362S	" "	" "
R511	QV25010-102	100 kΩ (C)	Slide Volume
R513	QRD141J-472S	4.7 kΩ 1/4 W	Carbon
R514	QRD141J-472S	4.7 kΩ "	" "
R515	QRD141J-821S	820 Ω "	" "
R516	QRD141J-821S	820 Ω "	" "
R601	QRD141J-222S	2.2 kΩ "	" "
R602	QRD141J-222S	2.2 kΩ "	" "
R603	QRD141J-104S	100 kΩ "	" "
R604	QRD141J-104S	100 kΩ "	" "
R605	QRD141J-202S	2 kΩ "	" "
R606	QRD141J-202S	" "	" "
R607	QRD141J-202S	" "	" "
R608	QRD141J-202S	" "	" "
R609	QRD141J-330S	33 Ω "	" "
R610	QRD141J-330S	" "	" "
R611	QRD141J-472S	4.7 kΩ "	" "
R612	QRD141J-472S	" "	" "
R613	QRD149J-121S	120 Ω "	" "
R614	QRD149J-121S	" "	" "
R615	QRD141J-152S	1.5 kΩ "	" "
R616	QRD141J-152S	1.5 kΩ "	" "
R617	QRD141J-393S	39 kΩ "	" "
R618	QRD141J-393S	39 kΩ "	" "
R619	QRD141J-392S	3.9 kΩ "	" "
R620	QRD141J-392S	3.9 kΩ "	" "
R621	QRD141J-392S	3.9 kΩ "	" "
R622	QRD141J-392S	3.9 kΩ "	" "
R623	QRD141J-271S	270 Ω "	" "
R624	QRD141J-271S	270 Ω "	" "
R625	QRD141J-271S	270 Ω "	" "
R626	QRD141J-271S	270 Ω "	" "
R627	QRD141J-823S	82 kΩ "	" "
R628	QRD141J-823S	82 kΩ "	" "
R629	QRD141J-133S	13 kΩ "	" "
R630	QRD141J-133S	13 kΩ "	" "
R631	QRD141J-681S	680 Ω "	" "
R632	QRD141J-751S	" "	" "
R633	QRD129J-562	5.6 kΩ 1/2 W	" Δ
R635	QRD149J-680S	68 Ω 1/4 W	" Δ
R637	QRD149J-680S	" "	" Δ
R641	QRD141J-221S	220 Ω "	" "
R642	QRD141J-561S	560 Ω "	" "
R643	ERT-D2WFL351S	350 Ω "	Thermistor
R644	ERT-D2WFL351S	" "	" "
R645	QVPA08-471	470 Ω "	Variable
R646	QVPA08-471	" "	" "
R647	QRD141J-431S	430 Ω 1/4 W	Carbon
R648	QRD141J-431S	430 Ω "	" "
R649	QRD141J-431S	430 Ω "	" "
R650	QRD141J-431S	430 Ω "	" "
R651	QRD149J-100S	10 Ω "	" Δ
R652	QRD149J-100S	10 Ω "	" Δ
R653	QRD149J-100S	10 Ω "	" Δ
R654	QRD149J-100S	10 Ω "	" Δ
R655	QRD149J-272S	2.7 kΩ "	" Δ
R656	QRD149J-272S	" "	" Δ
R657	QRD149J-471S	470 Ω "	" Δ
R658	QRD149J-471S	" "	" Δ
R659	ERF032K-R22	0.22 Ω 3 W	Cement
R660	ERF032K-R22	" "	" Δ
R661	QRX017J-100S	10 Ω 1 W	Oxide Metal Film Δ
R662	QRX017J-100S	" "	" Δ
R663	QRD129J-330	33 Ω 1/2 W	Carbon
R664	QRD129J-330	" "	" Δ
R665	QRD141J-103S	10 kΩ 1/4 W	" "

Item No.	Part Number	Rating	Description
R666	QRD141J-103S	10 kΩ 1/4 W	Carbon
R667	QRD141J-103S	10 kΩ "	" "
R668	QRD141J-103S	10 kΩ "	" "
R669	QRD141J-102S	1 kΩ "	" "
R670	QRD141J-102S	1 kΩ "	" "
R671	QRD141J-102S	1 kΩ "	" "
R672	QRD141J-102S	1 kΩ "	" "
R673	QRD141J-102S	1 kΩ "	" "
R674	QRD141J-102S	1 kΩ "	" "
R675	QRD141J-102S	1 kΩ "	" "
R676	QRD141J-102S	1 kΩ "	" "
R701	QRD141J-681S	680 Ω "	" "
R702	QRD141J-681S	680 Ω "	" "
R703	QRD141J-562S	5.6 kΩ "	" "
R704	QRD141J-562S	5.6 kΩ "	" "
R705	QRD141J-104S	100 kΩ "	" "
R706	QRD141J-104S	100 kΩ "	" "
R707	QRD141J-123S	12 kΩ "	" "
R708	QRD141J-123S	12 kΩ "	" "
R709	QRD141J-103S	10 kΩ "	" "
R710	QRD141J-104S	100 kΩ "	" "
R711	QRD141J-473S	47 kΩ "	" "
R712	QRD141J-683S	68 kΩ "	" "
R713	QRD141J-334S	330 kΩ "	" "
R714	QRD141J-682S	6.8 kΩ "	" "
R715	QRG017J-821S	820 Ω 1 W	Oxide Metal Film Δ
R716	QRD141J-223S	22 kΩ 1/4 W	" "
R717	QRD141J-153S	15 kΩ "	" "
R718	QRD141J-274S	270 kΩ "	" Δ
R719	QRD149J-100S	10 Ω "	" Δ
R720	QRD149J-100S	10 Ω "	" Δ
R721	QRD141J-332S	3.3 kΩ "	" "
R751	QRG017J-331S	330 Ω 1 W	Oxide Metal Film Δ
R752	QRG017J-331S	" "	" Δ
R753	QRD149J-100S	10 Ω 1/4 W	Carbon
R754	QRD149J-100S	10 Ω "	" Δ
R755	QRD149J-100S	" "	" Δ
R756	QRD149J-100S	" "	" Δ
R801	QRD149J-100S	" "	" Δ
R802	QRD149J-100S	" "	" Δ

## Others

Item No.	Part Number	Rating	Description
J301	EWR34A-20NN		Flat Wire Assy
	EWR35A-30NN		Flat Wire Assy
	EWR35A-30NN		Flat Wire Assy
	EWT011-01S		Terminal Wire Assy
	ESW013-11S		Socket Wire Assy
S601	QST4242-E02		Push Switch
RY701	ESK6D24-213		Relay
P404	QMV5005-003		3P Plug Assy
P801	QMV5005-003		3P Plug Assy
P802	QMV5005-004		4P Plug Assy
J751	E03572-007EM		Speaker Terminal
J752	E03572-007EM		Speaker Terminal
J753	QMS6302-105		Jack Assy
	E302175-001		Heat Sink
	E65396-001		Earth Plate (for B)
	E67292-001		Bracket (L)
	E67292-002		Bracket (R)
	S9S63008Z		Screw
	S9S63012Z		Screw
	E10701-001		Circuit Board

## 6-(3) TDS-6 □ Fluorescent Lamp P.C. Board Ass'y

Note: TDS-6□-1 varies according to the areas employed. See note (1) when placing an order.

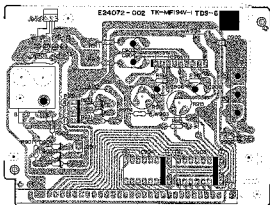

Fig. 12

### Transistors

Item No.	Part Number	Rating	Description	Maker
Q901	2SK105(H)			NEC
Q902	2SB507V(D,E)			Sanyo

### Integrated Circuits

Item No.	Part Number	Rating	Description	Maker
IC901	TA7318P(1,2)			Toshiba
IC903	HA12010			Hitachi
IC904	HA12010			Hitachi

### Diodes

Item No.	Part Number	Rating	Description	Maker
D901	RD18EB3	Zener		NEC
D902	RD2.7EB2	"	"	"
D931	RD8.2EB3	"	"	"
D932	RD8.2EB3	"	"	"

### Capacitors

Item No.	Part Number	Rating	Description
C903	QET51HR-105	1 μF 50 V	Electrolytic
C904	QET51HR-105	" "	"
C905	QET51HR-105	" "	"
C906	QET51HR-105	" "	"

Note (1)

Designated Areas	P.C. Board Ass'y
U.S.A. & Canada	TDS-6□
U.K.	TDS-6□
All Other Areas	TDS-6□

Note (2) The symbols (赤, 黒, 白 ... etc.) on P.C. Board surface are factory process only.

### Others

Item No.	Part Number	Rating	Description
J802	EWS014-067		Socket Wire Assy
P931	QMV5005-004		4P Plug Assy
	E81537-001		Heat Sink
	E67910-001		Spacer
	SBSB3008M		Screw
	ELU0001-010		Fluorescent Lamp
	E48269-001		Spacer (for D)
	E24072-002		Circuit Board

### Resistors

Item No.	Part Number	Rating	Description
R901	QRD141J-221S	220 Ω 1/4 W	Carbon
R902	QRD149J-2R2S	" "	"
R905	QRD149J-5R6S	5.6 Ω "	" (for A) △
R905	QRD149J-6R8S	6.8 Ω "	" (for B) △
R906	QRD149J-5R6S	5.6 Ω "	" (for A) △
R906	QRD149J-6R8S	" "	" (for B) △
R911	QRD141J-303S	30 kΩ	Carbon
R912	QRD141J-303S	" "	"
R913	QRD141J-471S	470 Ω	"
R914	QRD141J-471S	" "	"
R915	OVPA408-102	1 kΩ	Variable
R916	OVPA408-102	1 kΩ	"
R917	QRD141J-105S	1 MΩ 1/4 W	Carbon
R918	QRD141J-105S	" "	"
R931	QRD129J-470S	47 Ω "	" △
R933	QRZ0052-100	10 Ω 1/4 W	Fusible (for B,D) △

## 6-(4) TPS-255E AC P.C. Board Ass'y

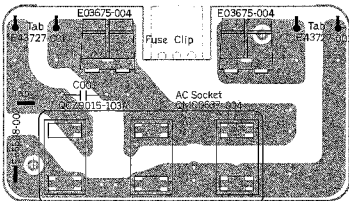

Fig. 13

Item No.	Part Number	Rating	Description
J811	QMC0837-004		AC Socket △
C001	QCZ9014-103A		0.01 μF Ceramic △
	E03675-004		Fuse Clip △
	E66003-004		Circuit Board △

## 6-(5) TPS-317 Fuse P.C. Board Ass'y

Note: TPS-317-1 varies according to the areas employed. See note (1) when placing an order.

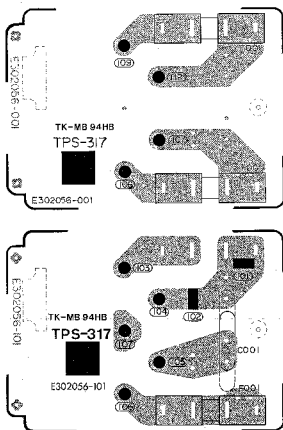

Fig. 14

Note (1)

Designated Areas	P.C. Board Ass'y
U.S. Military Market & Other Countries	TPS-317 $\Delta$
Europe, Australia	TPS-317 $\square$
U.K.	TPS-317 $\square$

Item No.	Part Number	Rating	Description
C001	QFZ9016-103		0.01 $\mu$ F Film (for B) $\Delta$
C001	QFZ9016-103SS		" (for CBS) $\Delta$
	EMG7931-001		Fuse Clip $\Delta$
	E302056-001		Circuit Board (for A)
	E302056-101		" (for B)
	E302056-101BS		" (for CBS)

Fig. 15

## 6-(6) TPS-318A Voltage Selector P.C. Board Ass'y

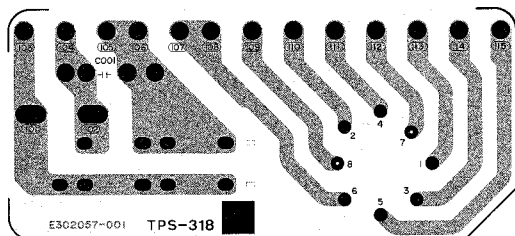
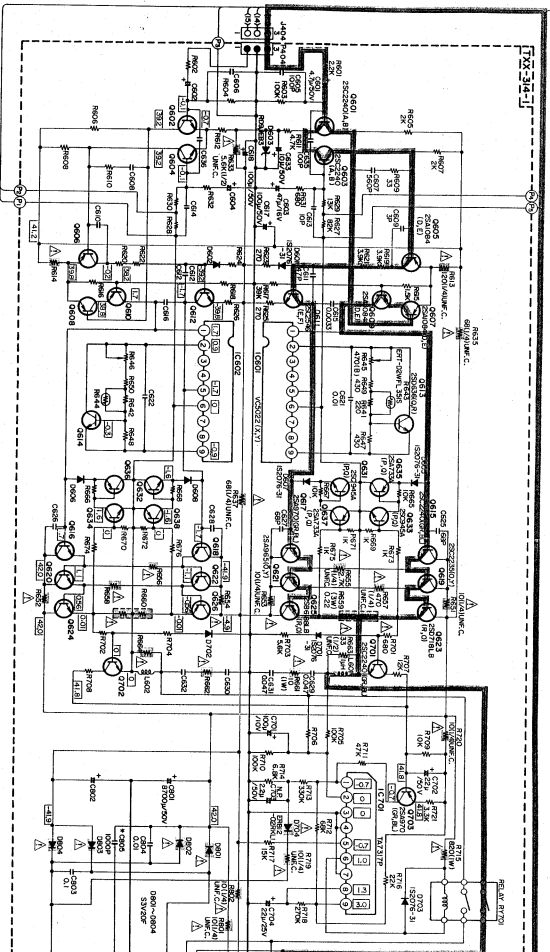
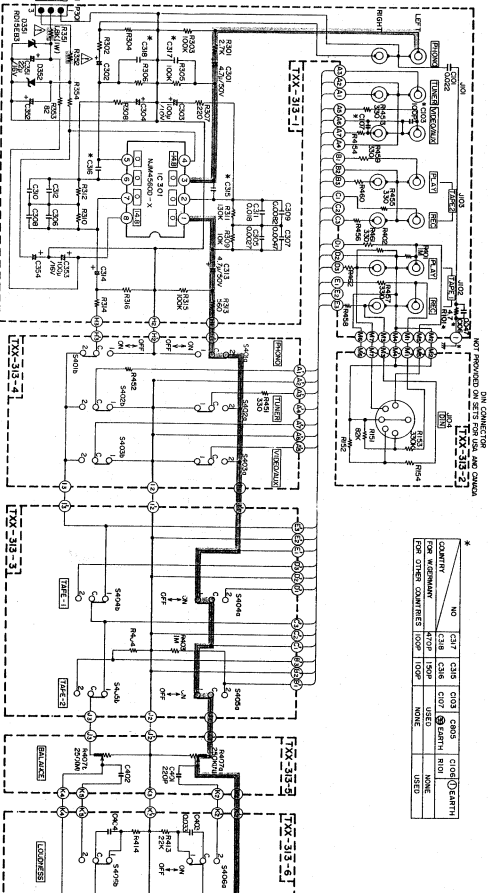

Fig. 16

Item No.	Part Number	Rating	Description
C001	QSR0085-006U		Voltage Selector $\Delta$
	QMC0637-004		AC Socket $\Delta$
	QFH53BM-103M		0.01 $\mu$ F Metalized $\Delta$
	E302057-001		Mylar Circuit Board

# 7. A-X30 Schematic Diagram



P.C. Board As'y	Description	Page
TXX-313	Equalizer and P.C. Board As'y	6
TXX-314	Main Amp. P.C. Board As'y	8
TDS-6	Fuser P.C. Board As'y	11
TFS-255E	AC P.C. Board As'y	11
TFS-317	Fuser P.C. Board As'y	12
TFS-318	Voltage Selector P.C. Board As'y	12

### Notes:

1. Voltage values in  $\square$  are positive.
2. Voltage values in  $\square$  are negative.
3.  $\square$  indicates positive B power supply.
4.  $\square$  indicates negative B power supply.
5.  $\square$  indicates signal path.
6. When replacing the parts in the darkened area ( ) and those marked with  $\Delta$ , be sure to use the designated parts to ensure safety.
7. Parts in red indicate transistors or ICs.
8. This is the standard circuit diagram.
9. The design and contents are subject to change without notice.

GROUP	CLASS	STATUS	DATE
CLASSIFIED	SECRET	APPROVED	1978
UNCLASSIFIED	SECRET	APPROVED	1978
UNCLASSIFIED	SECRET	APPROVED	1978

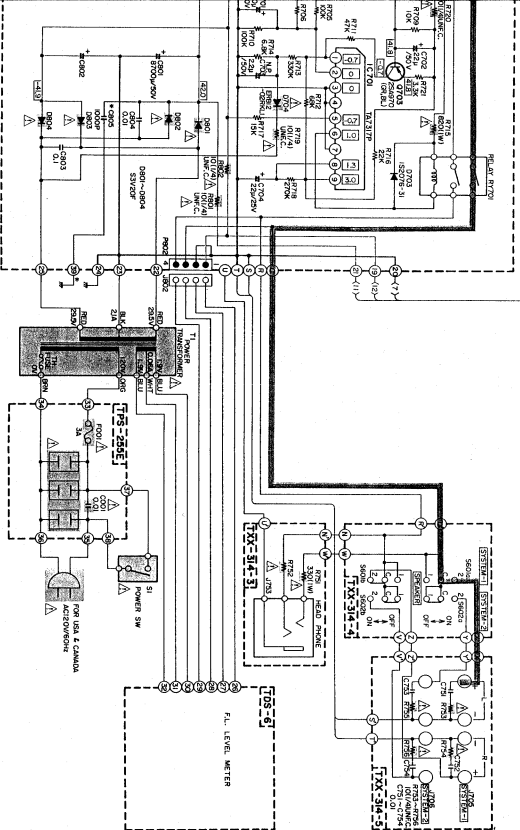
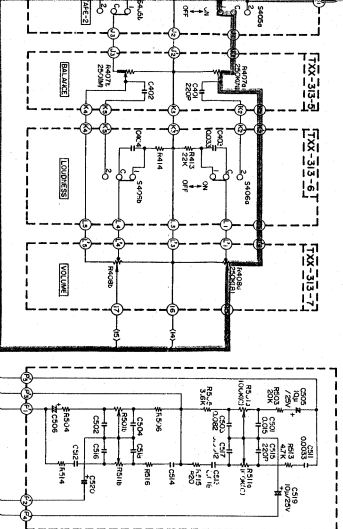

D E F

4 3 2 1

marked area ( ) and see the designated parts

to change without

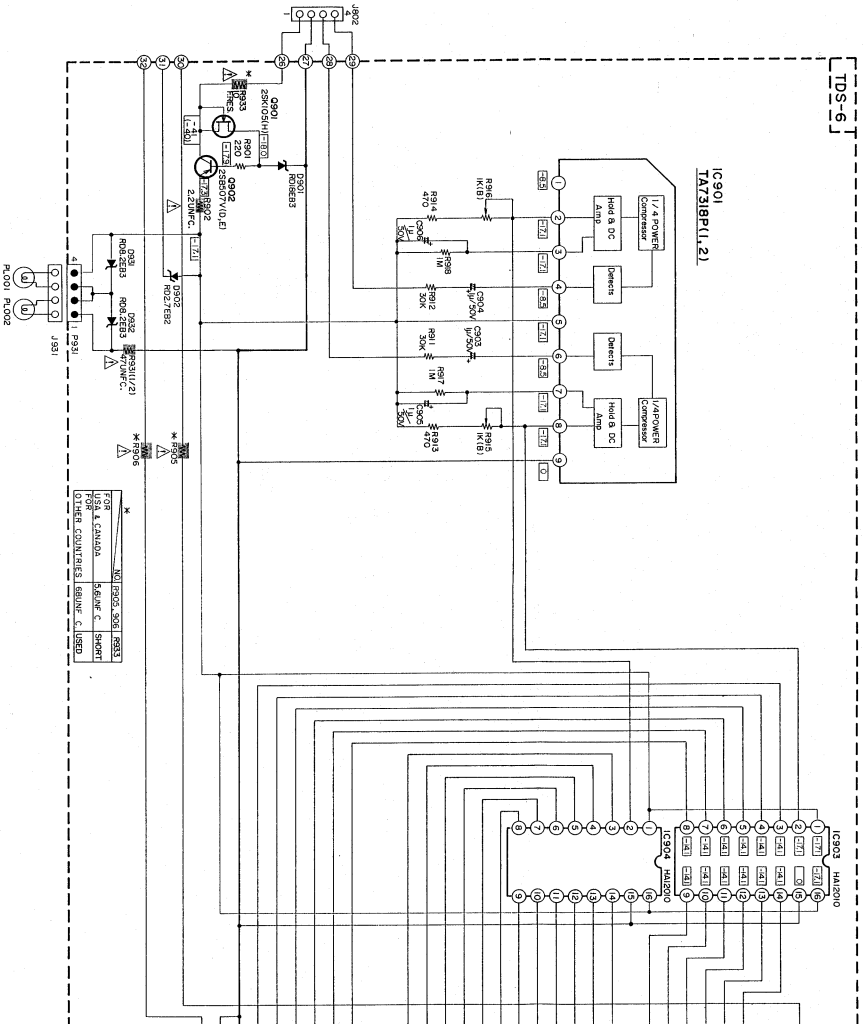

1	2	3	4	5	6	7	8	9	10	11	12	13	14	15	16	17	18	19	20	21	22	23	24	25
1	2	3	4	5	6	7	8	9	10	11	12	13	14	15	16	17	18	19	20	21	22	23	24	25

\* FOR U.S.A. & CANADA. \* FOR U.K. & AUSTRALIA. \* FOR EUROPE. \* FOR OTHER COUNTRIES. \* GROUND. \* USED.

**FOR U.K. and AUSTRALIA**

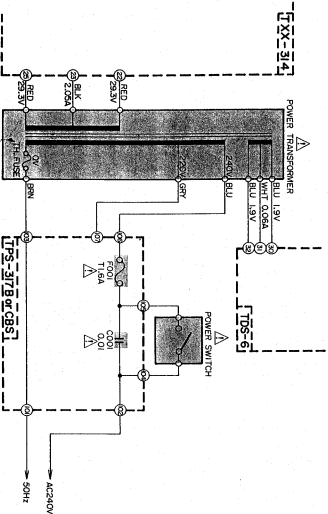

**FOR EUROPE**

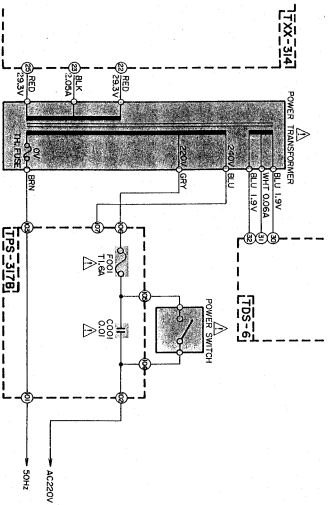

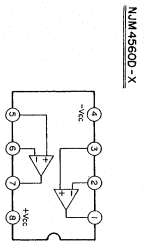
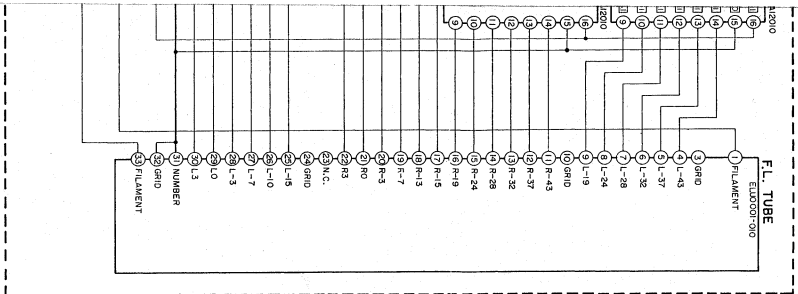

NIM 45600 - X

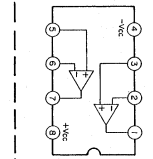

TAT317P

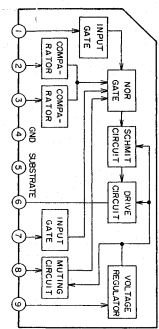

HA1200

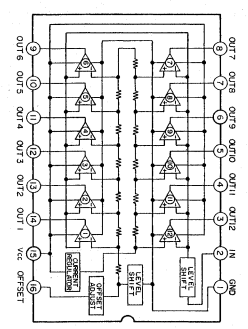

VOLTAGE SELECTOR CONNECTION

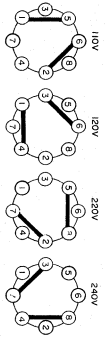

TOP VIEW

3297RHR (A) O	0263, 0264
3297RHR (A) 1	0263, 0264
3297RHR (A) 2	0263, 0264
3297RHR (A) 3	0263, 0264
3297RHR (A) 4	0263, 0264
3297RHR (A) 5	0263, 0264
3297RHR (A) 6	0263, 0264
3297RHR (A) 7	0263, 0264
3297RHR (A) 8	0263, 0264
3297RHR (A) 9	0263, 0264
3297RHR (A) 10	0263, 0264
3297RHR (A) 11	0263, 0264
3297RHR (A) 12	0263, 0264
3297RHR (A) 13	0263, 0264
3297RHR (A) 14	0263, 0264
3297RHR (A) 15	0263, 0264
3297RHR (A) 16	0263, 0264
3297RHR (A) 17	0263, 0264
3297RHR (A) 18	0263, 0264
3297RHR (A) 19	0263, 0264
3297RHR (A) 20	0263, 0264
3297RHR (A) 21	0263, 0264
3297RHR (A) 22	0263, 0264
3297RHR (A) 23	0263, 0264
3297RHR (A) 24	0263, 0264
3297RHR (A) 25	0263, 0264
3297RHR (A) 26	0263, 0264
3297RHR (A) 27	0263, 0264
3297RHR (A) 28	0263, 0264
3297RHR (A) 29	0263, 0264
3297RHR (A) 30	0263, 0264
3297RHR (A) 31	0263, 0264
3297RHR (A) 32	0263, 0264
3297RHR (A) 33	0263, 0264
3297RHR (A) 34	0263, 0264
3297RHR (A) 35	0263, 0264
3297RHR (A) 36	0263, 0264
3297RHR (A) 37	0263, 0264
3297RHR (A) 38	0263, 0264
3297RHR (A) 39	0263, 0264
3297RHR (A) 40	0263, 0264
3297RHR (A) 41	0263, 0264
3297RHR (A) 42	0263, 0264
3297RHR (A) 43	0263, 0264
3297RHR (A) 44	0263, 0264
3297RHR (A) 45	0263, 0264
3297RHR (A) 46	0263, 0264
3297RHR (A) 47	0263, 0264
3297RHR (A) 48	0263, 0264
3297RHR (A) 49	0263, 0264
3297RHR (A) 50	0263, 0264
3297RHR (A) 51	0263, 0264
3297RHR (A) 52	0263, 0264
3297RHR (A) 53	0263, 0264
3297RHR (A) 54	0263, 0264
3297RHR (A) 55	0263, 0264
3297RHR (A) 56	0263, 0264
3297RHR (A) 57	0263, 0264
3297RHR (A) 58	0263, 0264
3297RHR (A) 59	0263, 0264
3297RHR (A) 60	0263, 0264
3297RHR (A) 61	0263, 0264
3297RHR (A) 62	0263, 0264
3297RHR (A) 63	0263, 0264
3297RHR (A) 64	0263, 0264
3297RHR (A) 65	0263, 0264
3297RHR (A) 66	0263, 0264
3297RHR (A) 67	0263, 0264
3297RHR (A) 68	0263, 0264
3297RHR (A) 69	0263, 0264
3297RHR (A) 70	0263, 0264
3297RHR (A) 71	0263, 0264
3297RHR (A) 72	0263, 0264
3297RHR (A) 73	0263, 0264
3297RHR (A) 74	0263, 0264
3297RHR (A) 75	0263, 0264
3297RHR (A) 76	0263, 0264
3297RHR (A) 77	0263, 0264
3297RHR (A) 78	0263, 0264
3297RHR (A) 79	0263, 0264
3297RHR (A) 80	0263, 0264
3297RHR (A) 81	0263, 0264
3297RHR (A) 82	0263, 0264
3297RHR (A) 83	0263, 0264
3297RHR (A) 84	0263, 0264
3297RHR (A) 85	0263, 0264
3297RHR (A) 86	0263, 0264
3297RHR (A) 87	0263, 0264
3297RHR (A) 88	0263, 0264
3297RHR (A) 89	0263, 0264
3297RHR (A) 90	0263, 0264
3297RHR (A) 91	0263, 0264
3297RHR (A) 92	0263, 0264
3297RHR (A) 93	0263, 0264
3297RHR (A) 94	0263, 0264
3297RHR (A) 95	0263, 0264
3297RHR (A) 96	0263, 0264
3297RHR (A) 97	0263, 0264
3297RHR (A) 98	0263, 0264
3297RHR (A) 99	0263, 0264
3297RHR (A) 100	0263, 0264

FOR OTHER COUNTRIES

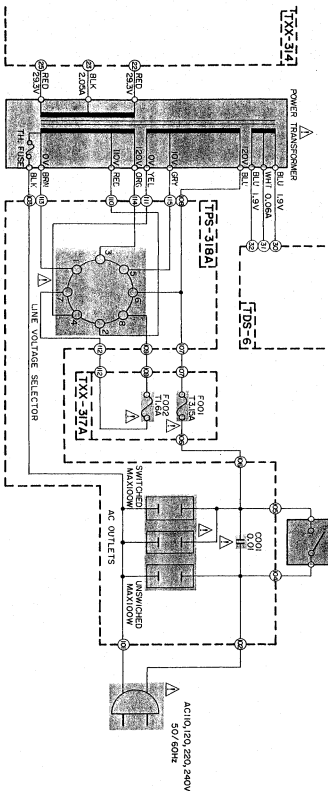



## 8. Packing Materials and Part Numbers

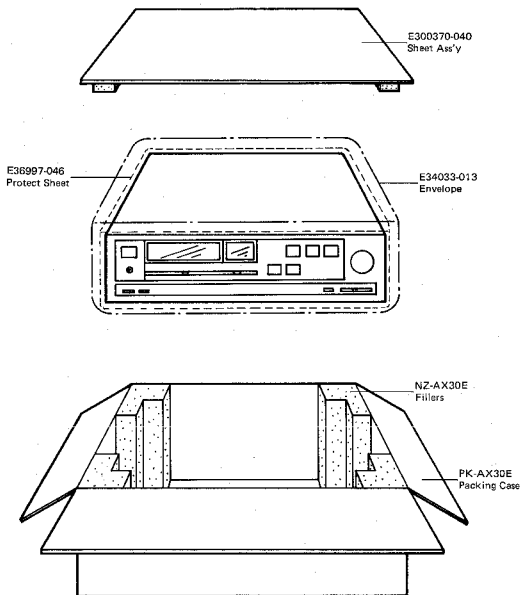

Fig. 17

## 9. Accessories List

Description	USA (& Canada)	Europe (& West Germany)	U.K.	Australia	U.S. Military Market (& Other Countries)
Instruction Book	E30580-985A { " }	E30580-985A { " }	E30580-985ABS	E30580-985A	E30580-985A { " }
Warranty Card	BT20048 (BT20025E)	-	BT20013C	BT20029C	- (BT20048)
Service Information Card	BT20046A { - }	-	-	-	- (BT20046A)
Safety Instruction	BT20044B { - }	-	-	-	-
Envelope	E41202-2 { " }	E41202-2 { " }	E41202-2	E41202-2	E41202-2 { " }
Siemens Plug	-	-	-	-	E04056 { " }

## 10. Parts List with Specified Numbers for Designated Areas

Item No.	Description	USA (& Canada)	Europe (& West Germany)	U.K.	Australia	US Military Market (& Other Countries)
1	Power Transformer <sup>△</sup>	ETP1150-06JA (ETP1150-06CA)	ETP1150-06EA ( " )	ETP1150-06EABS	ETP1150-06EA	ETP1150-06FA ( " )
2	Power Switch <sup>△</sup>	OSP1110-309 ( " )	OSP1110-305 ( " )	OSP1110-305BS	OSP1110-305	OSP1110-305 ( " )
3	Power Switch Cover	-	E301869-001 ( " )	E301869-001	E301869-001	E301869-001 ( " )
4	Power Cord <sup>△</sup>	QMP1200-200 ( " )	QMP3900-200 ( " )	QMP9017-008BS	QMP2560-244	QMP7600-250 ( " )
5	Fuse (Primary) <sup>△</sup>	QMF61U1-3R0 ( " )	QMF51A2-1R6L ( " )	OMF51A21R6LBS	QMF51A2-1R6L	QMF51A2-3R15S ( " )
6	Fuse (Primary) <sup>△</sup>	-	-	-	-	QMF51A2-1R6L ( " )
7	Fuse Label	E61378-009 (E67492-3R0)	E67132-T1R6 ( " )	E67132-T1R6	E67132-T1R6	E67132-T3R15 ( " ) E67132-T1R6 ( " )
8	AC Fuse & Voltage Selector P.C. Board Ass'y <sup>△</sup>	TPS-255E ( " )	TPS-317B ( " )	TPS-317CBS	TPS-317B	TPS-317A ( " ) TPS-318A ( " )
9	Voltage Selector <sup>△</sup>	-	-	-	-	QSR0085-006U ( " )
10	Fastener	-	E34455-001 ( " )	E34455-001	E34455-001	E34455-001 ( " )
11	Protect Cover	-	E69401-001 ( " )	E69401-001	E69401-001	-
12	Equalizer & Select Switch P.C. Board Ass'y	TXX-313A ( " )	TXX-313B (TXX-313C)	TXX-313B	TXX-313B	TXX-313B ( " )
13	Fluorescent Lamp P.C. Board Ass'y	TDS-6A ( " )	TDS-6B ( " )	TDS-6D	TDS-6B	TDS-6B ( " )
14	Rear Panel	E24127-001 ( " )	E24127-002 ( " )	E24127-002	E24127-002	E24127-003 ( " )
15	Wire Clamp	PU49485-2 ( " )	-	-	-	-
16	DIN Socket	-	E03623-003	E03623-003	E03623-003	E03623-003 ( " )

<sup>△</sup>: Safety Parts

# JVC

VICTOR COMPANY OF JAPAN, LIMITED, TOKYO, JAPAN